

NOTES:

- 1. APPLICABLE STANDARDS/SPECIFICATIONS
  - A. ASME Y14.5M-1994, DIMENSIONS AND TOLERANCES
  - B. ASME Y14.38-2007, ABBREVIATIONS AND ACRONYMS
- 2. FOR SALE REFERENCE ONLY

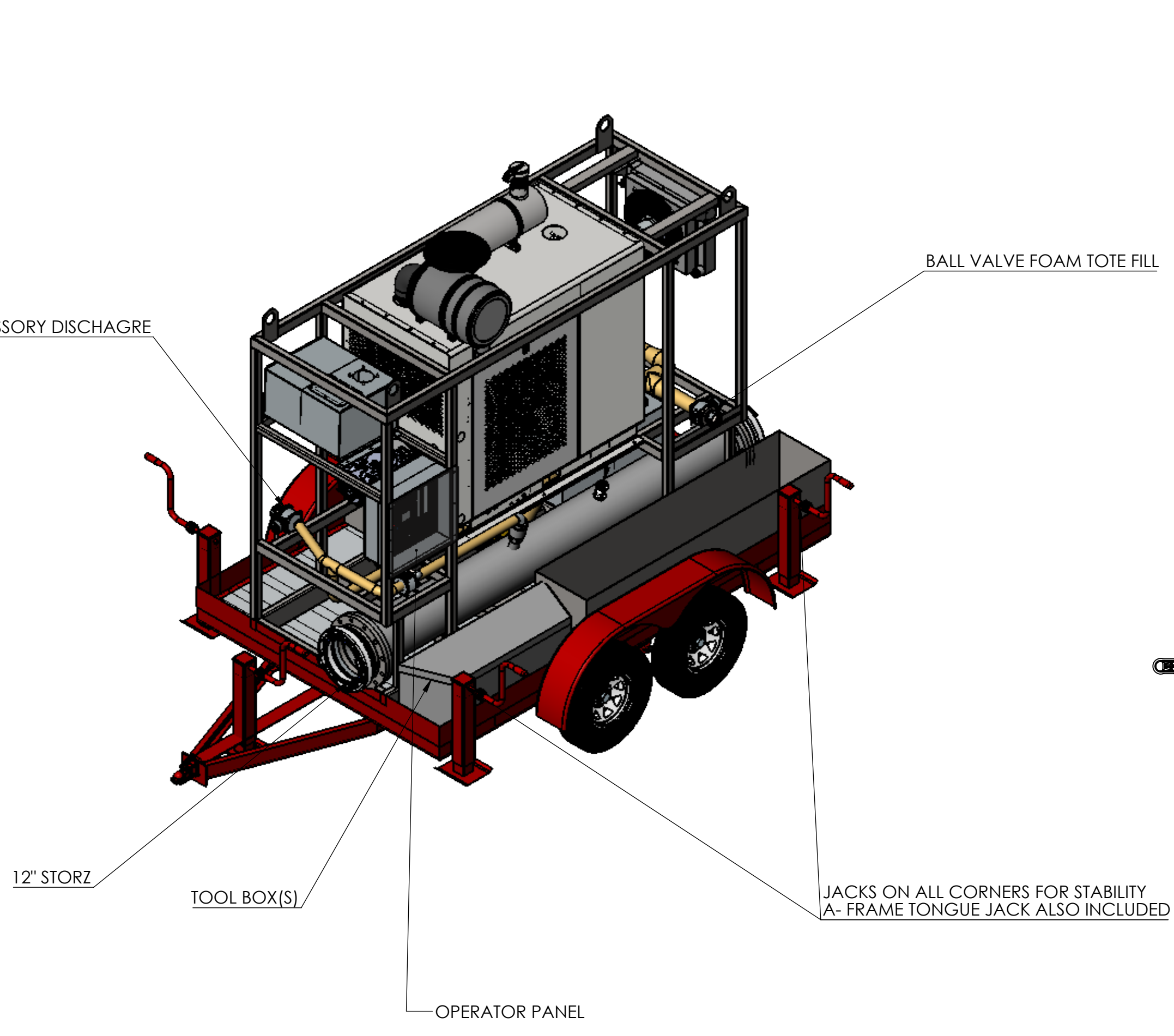

FOAM PRO ACCUMAX 3300 SINGLE POINT SYSTEM  
 FOAM DISCHARGE 12.0 GPM (45 LPM) - 300 GPM (1,136 LPM)  
 1% CONCENTRATION FLOW 30,000 GPM ( 113,356 LPM)  
 3% CONCENTRATION FLOW 10,000 GPM ( 37,854 LPM)  
 6% CONCENTRATION FLOW 5,000 GPM ( 18,927 LPM)

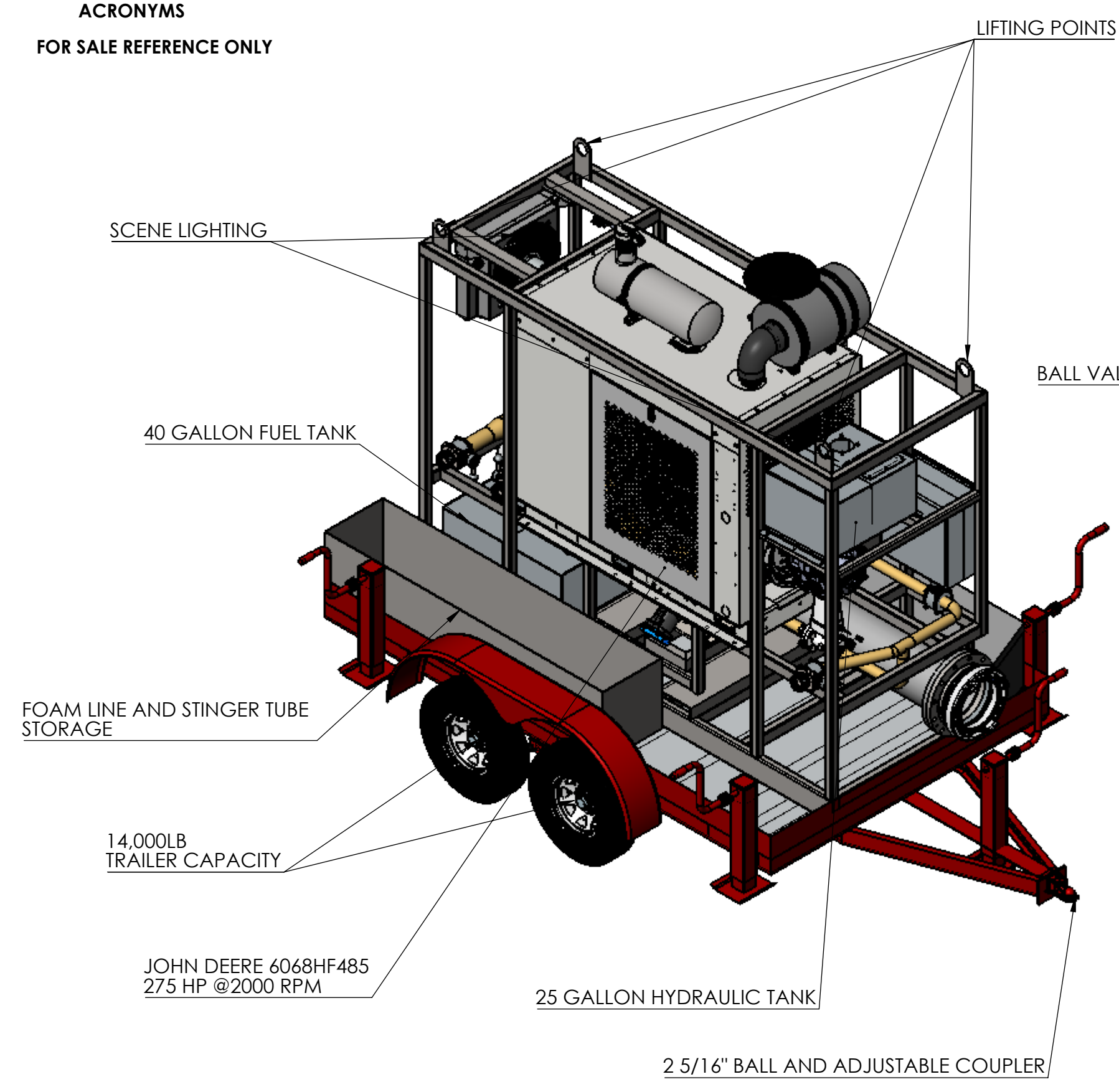
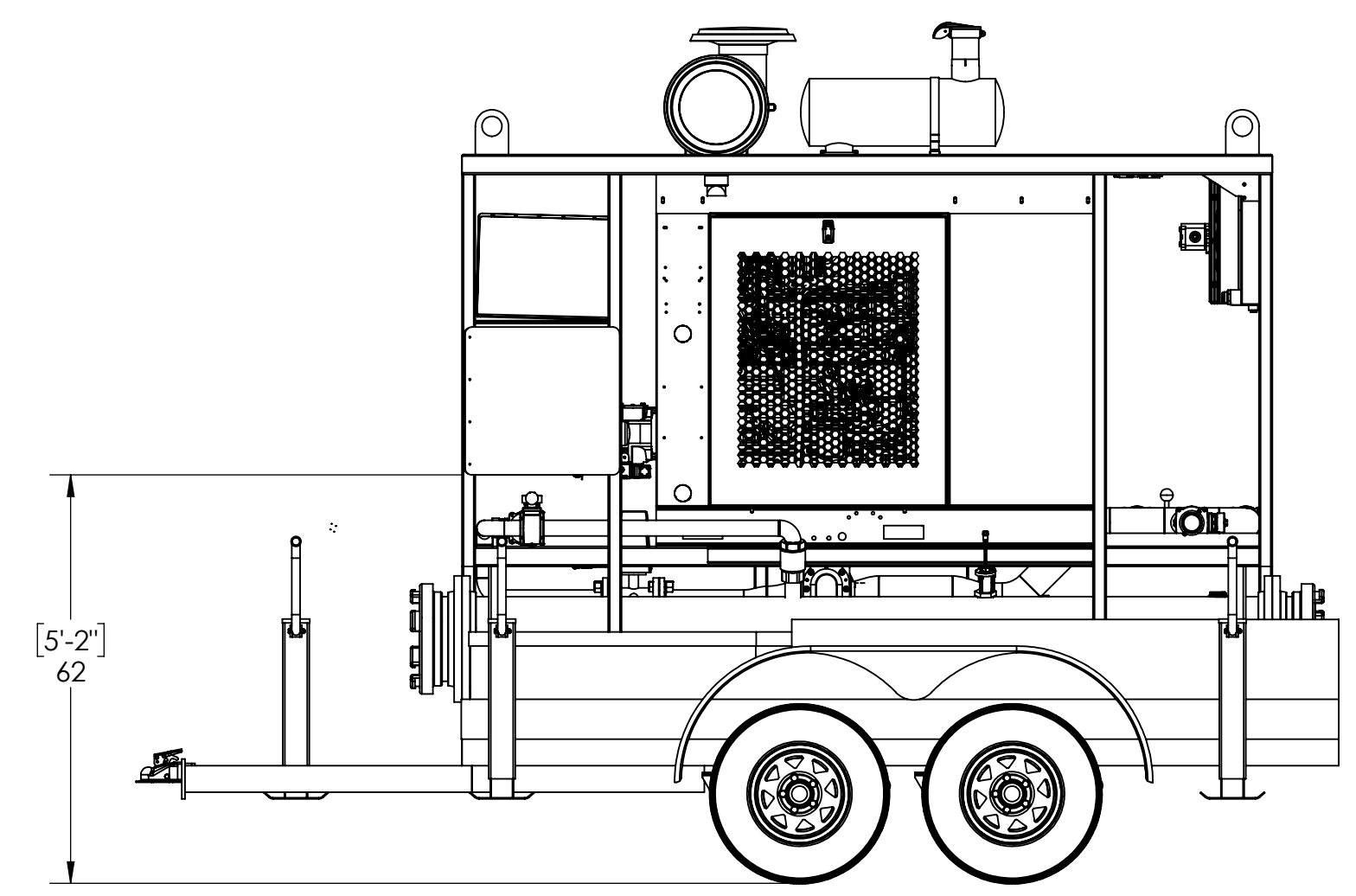
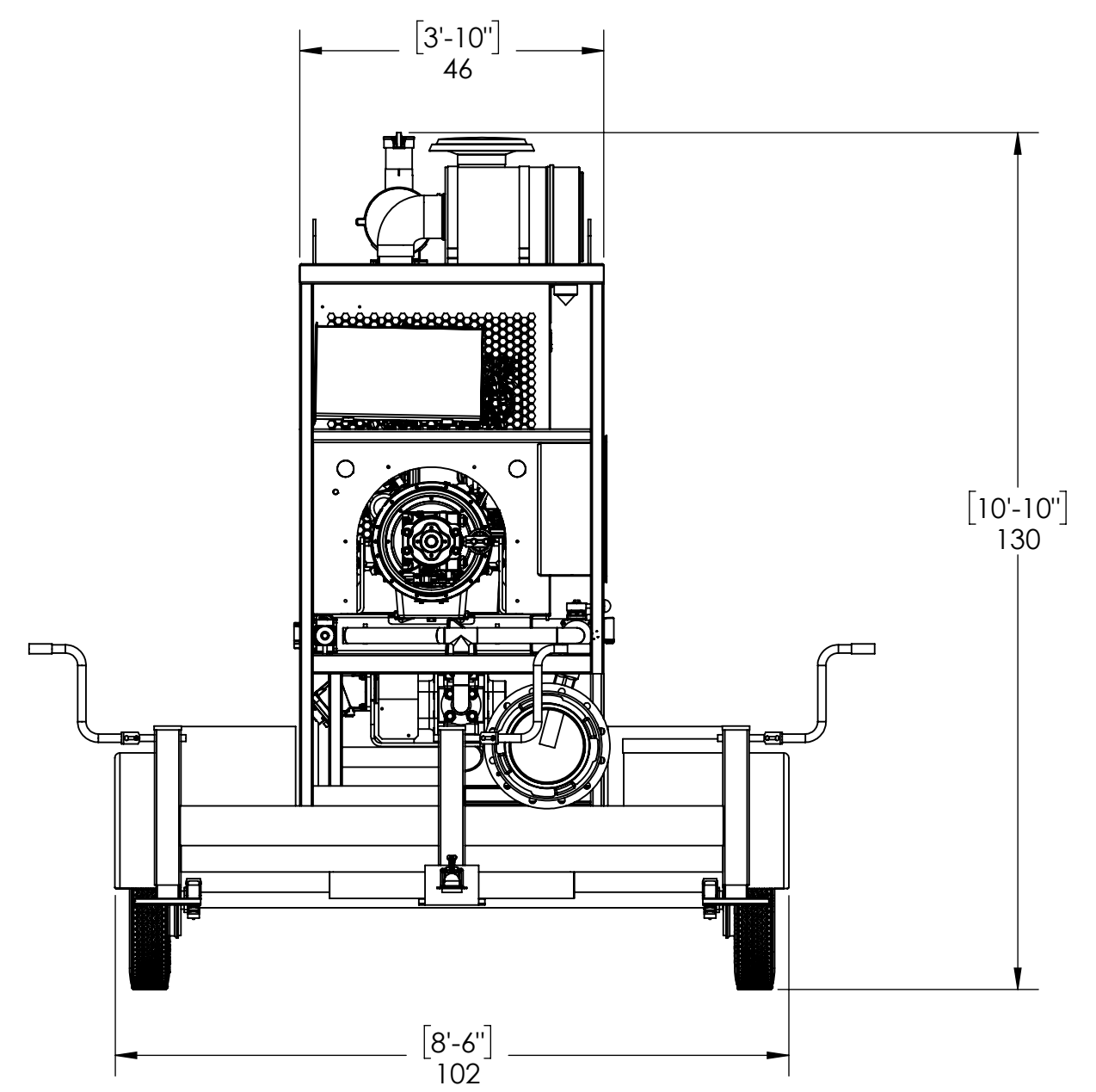
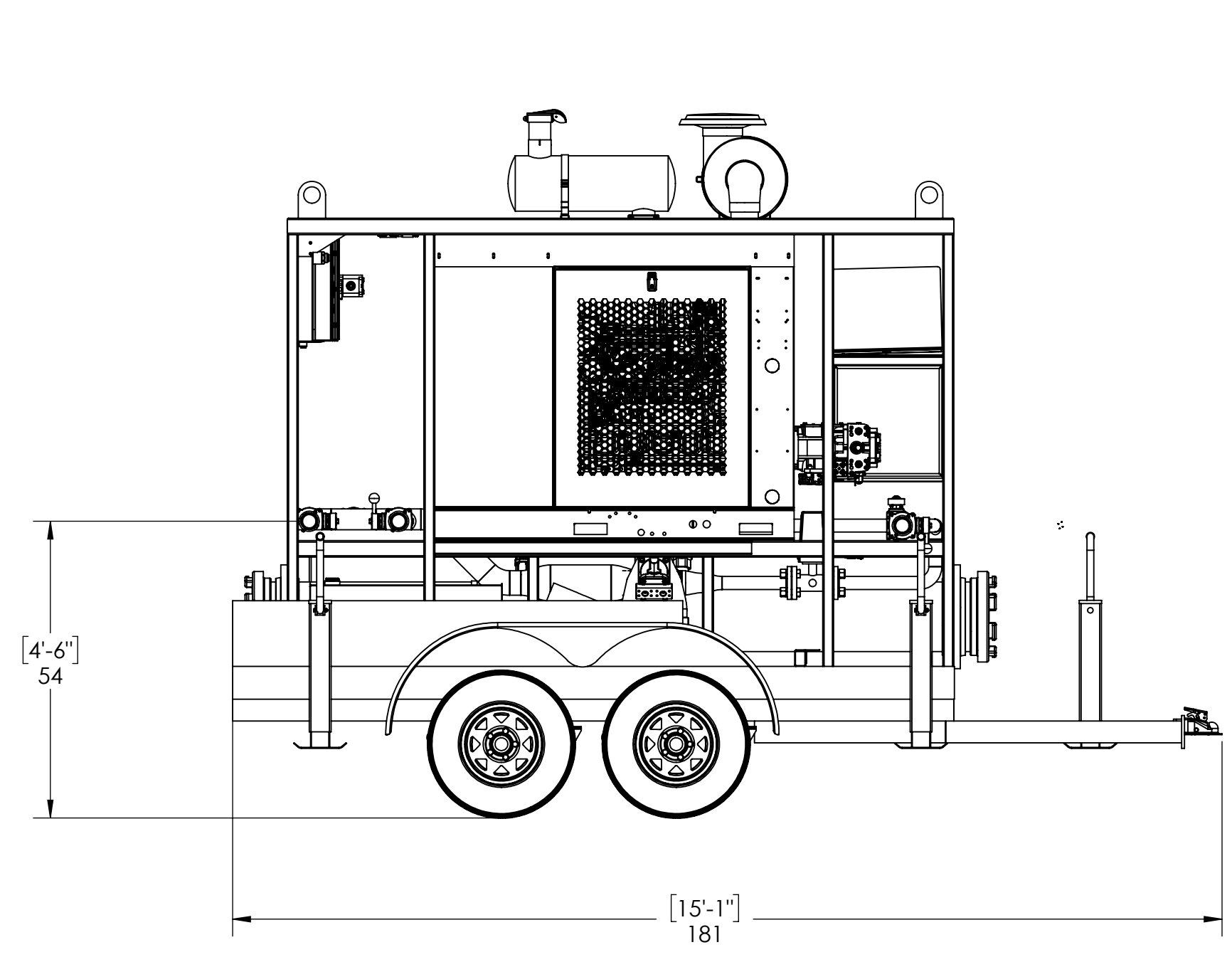
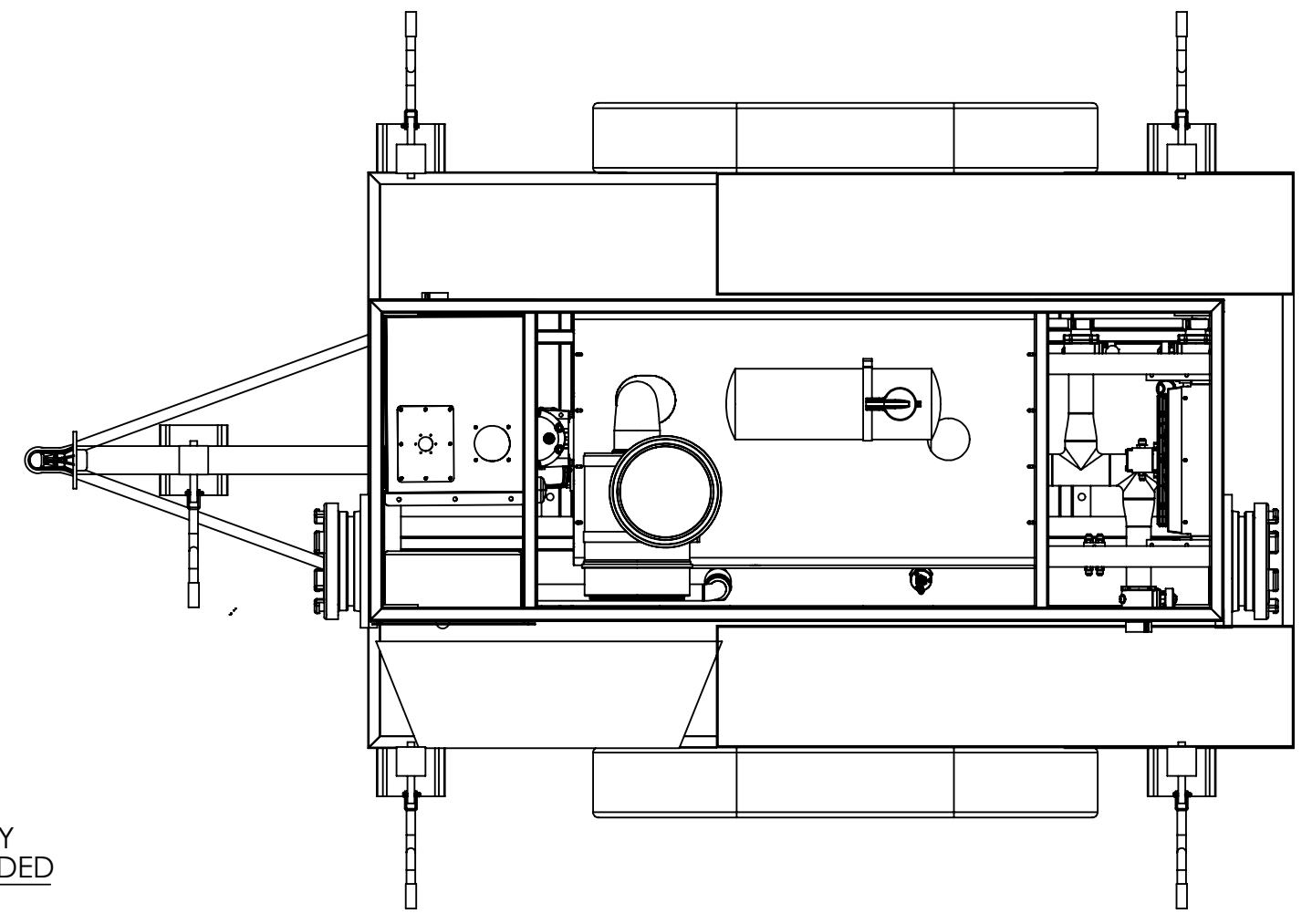

THE INFORMATION CONTAINED HEREIN IS PROPRIETARY DATA, AND IS NOT FOR DISSEMINATION OR DISCLOSURE, IN WHOLE OR IN PART, FOR ANY PURPOSE OTHER THAN THAT FOR WHICH IT IS SUBMITTED, EXCEPT AS AUTHORIZED IN WRITING BY US FIRE PUMP.

DELIVERY MUST CONFORM EXACTLY WITH DRAWING SPECIFICATIONS AND APPROVED Q.A. SAMPLES. ABSOLUTELY NO CHANGES ARE PERMITTED WITHOUT PRIOR APPROVAL BY US FIRE PUMP. THIS INCLUDES CHANGES TO: SOFTWARE, MATERIALS, INTERNAL COMPONENTS, MANUFACTURING PROCESSES.

INCH

ADDITIONAL APPROVALS	DATE								
STRESS									
MATERIALS & PROCESSES									
QUALITY ASSURANCE									
MANUFACTURING ENGINEERING									
TREATMENT									
DASH NO.		NEXT ASSY		USED ON					
APPLICATION									
PROJECTION		THIRD ANGLE		FINISH					

UNLESS OTHERWISE SPECIFIED DIMENSIONS ARE IN INCHES. TOLERANCES ARE: DECIMALS: .XX ± 0.02 XXX ± 0.010 SHEET METAL DIMENSIONS: ± 0.015		PROJECT		DATE	
DO NOT SCALE DRAWING		APPROVALS		DATE	
		DRAWN		30JUN21	
		CHECKED		30JUN21	
		DESIGNER		30JUN21	
		APPROVED		30JUN21	



**300 GPM DIRECT FOAM INJECTION SKID, TANDEM AXLE TRAILER**

SIZE	CAGE CODE	DWG NO	REV
D	-	DFIS_4 with trailer	-
SCALE	RELEASE DATE	WEIGHT	SHEET
1:25	-	8523.49 lbs.	1 of 1