

CAGE	DWG NO	Skid Assembly		SH	1	REV	-	1
REVISIONS								
ZONE	REV.	DESCRIPTION	DATE	APPROVED				
	-	INITIAL RELEASE, FOR G.A.	11/26/24	C.J.G				

STAINLESS PLATE LOCATED IN EACH TOTE SLOT TO PROTECT DECK AND GIVE SLIDING SURFACE FOR TOTES TO LOAD/ UNLOAD

TOTES ARE PLUMBED INTO 3" MANIFOLD, AND CAN BE INDIVIDUALLY OPEN/ CLOSED VIA 2" BALL VALVES FOR EACH TOTE

FOAM MANIFOLD, 3" PIPE

QTY. 6 IBC TOTES (NOT INCLUDED)

FOR SL222 HOOKLIFT, OTHER MODELS AVAILABLE UPON CUSTOMER REQUEST

QTY. 3 - 3" BALL VALVES LOCATED AROUND THE SKID FOR QUICK ACCESS TO FOAM

OUTLET IN 3" MALE CAMLOCK

NOTES:

1. APPLICABLE STANDARDS/SPECIFICATIONS
  - A. ASME Y14.5M-1994, DIMENSIONS AND TOLERANCES
  - B. ASME Y14.38-2007, ABBREVIATIONS AND ACRONYMS
2. DESIGN MODEL IS REPRESENTED IN CAD DIGITAL DATA FILE. DESIGN MODEL AVAILABLE IN OTHER 2D AND 3D DIGITAL DATA FORMATS ON REQUEST. INTERPRET PER ASME Y14.41-2003.
3. FOAM MANIFOLD IS 304 STAINLESS STEEL
4. HOOKLIFT SKID IS CARBON STEEL
5. NUMBER OF TOTES IS DEPENDENT ON SIZE AND CAPACITY OF HOOKLIFT MODEL

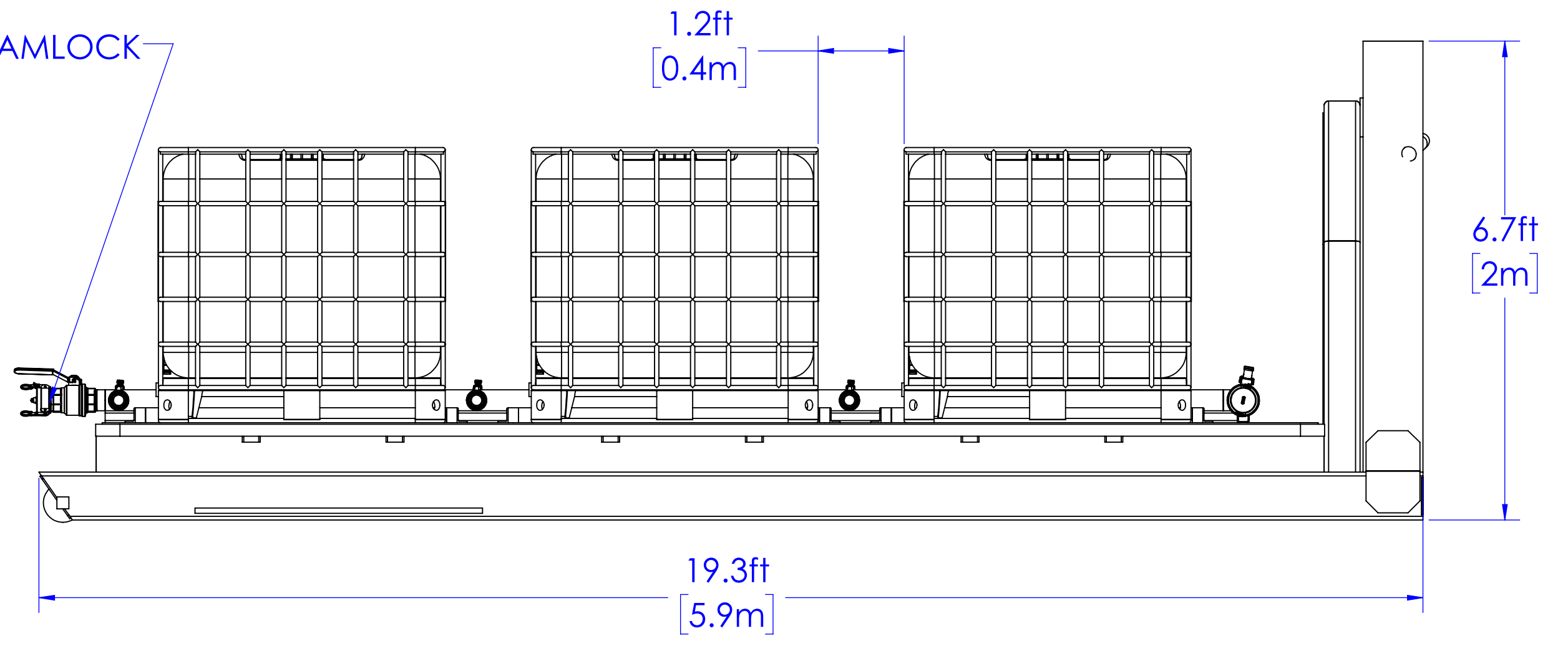
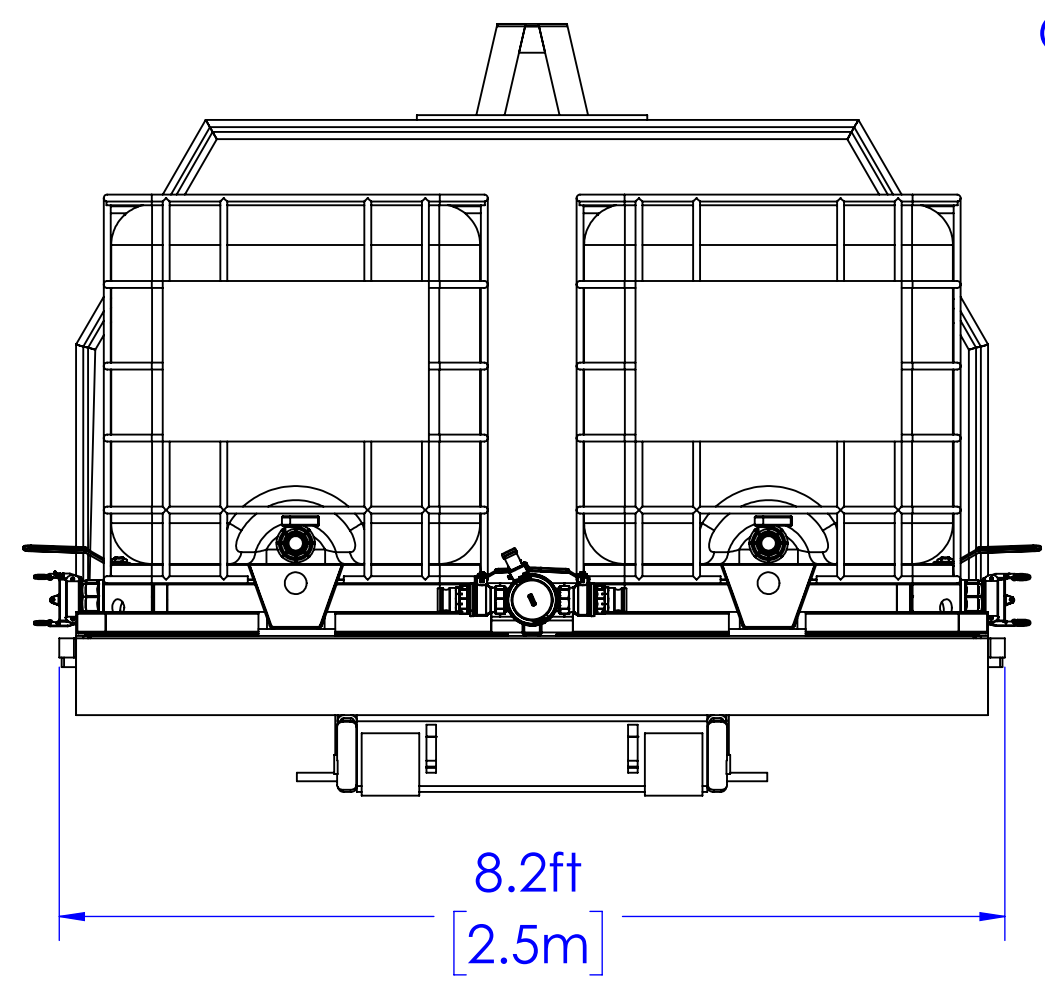

THE INFORMATION CONTAINED HEREIN IS PROPRIETARY DATA, AND IS NOT FOR DISSEMINATION OR DISCLOSURE, IN WHOLE OR IN PART, FOR ANY PURPOSE OTHER THAN THAT FOR WHICH IT IS SUBMITTED, EXCEPT AS AUTHORIZED IN WRITING BY US FIRE PUMP.

DELIVERY MUST CONFORM EXACTLY WITH DRAWING SPECIFICATIONS AND APPROVED Q.A. SAMPLES. ABSOLUTELY NO CHANGES ARE PERMITTED WITHOUT PRIOR APPROVAL BY US FIRE PUMP. THIS INCLUDES CHANGES TO: SOFTWARE, MATERIALS, INTERNAL COMPONENTS, MANUFACTURING PROCESSES.

INCH

ADDITIONAL APPROVALS	DATE					UNLESS OTHERWISE SPECIFIED DIMENSIONS ARE IN INCHES. TOLERANCES ARE: DECIMALS: .XX ± 0.02 ANGLES: ± 0.5° XXX ± 0.010 SHEET METAL DIMENSIONS: ± 0.015 DO NOT SCALE DRAWING	PROJECT	
STRESS							APPROVALS	DATE
MATERIALS & PROCESSES							C.J.G	-
QUALITY ASSURANCE							CHECKED	-
MANUFACTURING ENGINEERING	DASH NO	NEXT ASSY	USED ON				DESIGNER	-
TREATMENT	APPLICATION						APPROVED	-
	PROJECTION	THIRD ANGLE				FINISH	BLACK	
							PROJECT TITLE	
							FOAM TOTE SKID, WITH MANIFOLD, FOR SL222 SWAPLOADER, 6 TOTE CAPACITY	
							SIZE	D
							CAGE CODE	-
							DWG NO	Skid Assembly
							SCALE	1:20
							RELEASE DATE	-
							WEIGHT	17000.000.LBS
							SHEET	1 of 1