

HG35-001 Nozzle

Description

Have the power of Foam, Water, and Dry Chemical in the palm of your hand! The HG35-001 Nozzle is a dual agent nozzle capable of flowing Water/foam solution along with Dry Chemical solution when fed from a Foam proportioning system and Dry Chemical unit.

Separate control valve handles allow the user to control flow of Water/foam and dry chemical independently. Both inlets are 1.5" FNST swivels to make connecting this nozzle a breeze. Intuitive controls allow the control of stream and flow.

See our Dry Chemical webpage to see our available units to compliment this handy tool!

Features

- Heavy Duty Aluminum Construction
- 1.5" FNST Swivel Inlets
- Removable Pistol Grip with Mounting Rail
- Selectable flow 60 - 125 GPM (227 – 473 LPM)
- Selectable Flow Pattern
- Flow up to 12 lbs/sec of Dry Chem

Note: Contact US Fire Pump Sales Department for more information

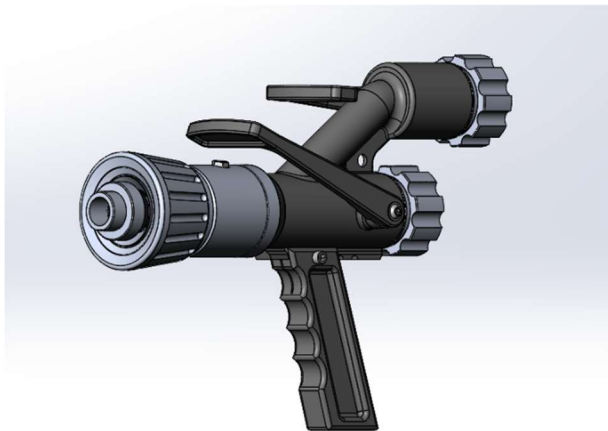

Application

- Oil Refineries and Chemical Plants
- Airports and Aviation facilities
- Hazardous Material Response Teams
- Power Generation Stations
- Industrial Warehouses



Post Office Box 1810, Albany, LA 70711

Phone: 225-209-6551 • Email: info@usfirepump.com • www.usfirepump.com