

2K Dry Chemical Unit

Description

The Dry Chemical Trailer Unit is a mobile firefighting and hazard suppression system designed for rapid deployment in industrial, petrochemical, and emergency response scenarios. It provides an effective means to extinguish Class B and C fires by delivering a high-capacity discharge of dry chemical extinguishing agents.

Features

- 2,000 lbs. (907 kg) of ABC or BC dry chem agent
- Discharge Rate: 14 lb/sec (6.4 kg/sec)
- Discharge Range: up to 60-80 ft (18.2-24.3 m)
- Easily Refill through the locking port on top of canister
- Propellant: Compressed nitrogen or CO2
- Bumper Pull Pintle hitch or 2-5/16 ball
- Heavy Duty Steel Frame with Rust resistant finish
- 100 ft (30.5 m) of Hose per Reel
- Removable skid unit from trailer



Application

- Oil refineries and chemical plants
- Airports and aviation facilities
- Hazardous material response teams
- Power generation stations
- Industrial warehouses

NOTICE Although the information and recommendations set forth herein (hereinafter “information”) are presented in good faith and believed to be correct as of the date hereof, US FIRE PUMP and its affiliates makes no representations or warranties as to the completeness or accuracy thereof. Information is supplied on the condition that the persons receiving same will make their own determination as to its suitability for their purposes prior to use. In no event will US FIRE PUMP be responsible for damages of any nature whatsoever resulting from the use of or reliance upon information or the product to which the information refers. Nothing contained herein is to be construed as a recommendation to use any product, process, equipment or formulation in conflict with any patent, and US FIRE PUMP makes no representation or warranty, express or implied, that the use thereof will not infringe any patent. NO REPRESENTATIONS OR WARRANTIES, EITHER EXPRESSED OR IMPLIED, OF MERCHANTABILITY, FITNESS FOR A PARTICULAR PURPOSE OR OF ANY OTHER NATURE ARE MADE HEREUNDER WITH RESPECT TO INFORMATION OR THE PRODUCT TO WHICH INFORMATION REFERS.

FOR MORE INFORMATION VISIT WWW.USFIREPUMP.COM

US FIRE PUMP COMPANY, LLC
 27995 James Chapel Road North, Holden, LA 70744
 MAILING: PO Box 1810, Albany, LA 70711

EMERGENCY 24 HOUR RESPONSE: (225) 209-6551



USFP-202503-6

Technical Data	
Base Material	Carbon Steel
Unit Gross Weight (Loaded)	7,000 lbs. (3175 kg.)
Unit Dimensions (LxWxH)	200 x 102 x 84" (508 x 259 x 213 cm)
Skid Weight	5000 lbs. (2268 kg.)
Operating Temp	120* F
Hose Diameter	1" (2.54 cm)
Nitrogen Cylinder	(4) 300 CF cylinders (8495 L)
Pressure Relief	250 PSI (1723.7 Kpa)

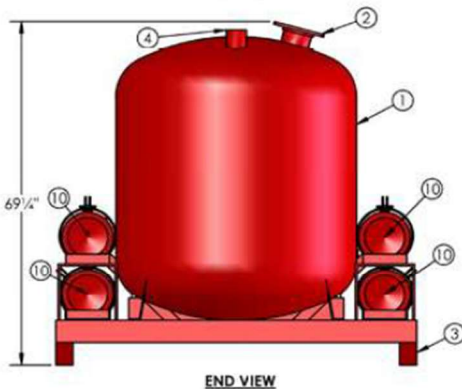
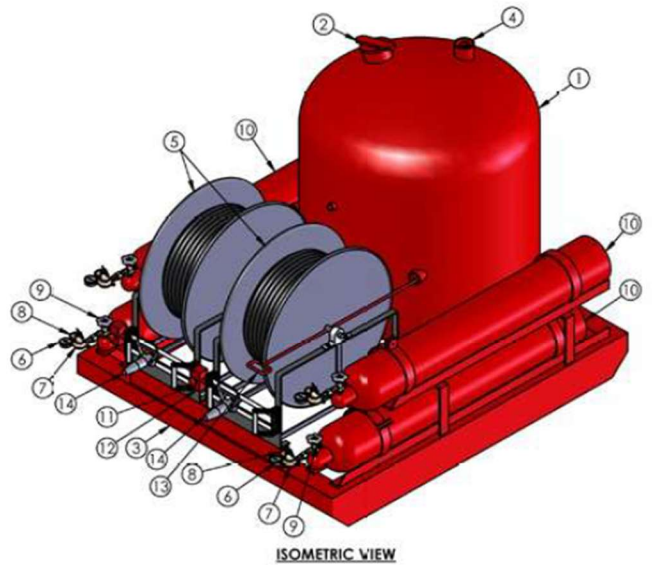
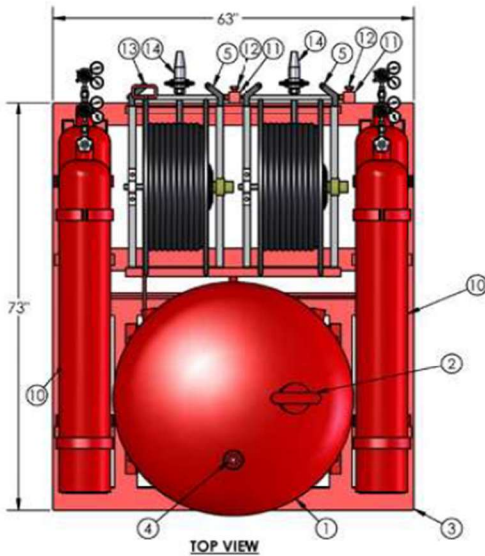

2000 LB DRY CHEMICAL UNIT

EMPTY WEIGHT - 3,000 lbs
 FULL WEIGHT - 5,000 lbs

ITEM NO.	UNIT DESCRIPTION
1	A.S.M.E. CODE CYLINDER - 42" O.D.
2	4" FILLER CAP
3	SKID ASSEMBLY
4	250 POP-OFF
5	HOSE REEL MANUAL REWIND W/ 100FT 1" HOSE
6	REGULATOR PRESSURE GAUGE
7	NITROGEN REGULATOR
8	HIGH PRESSURE GAUGE
9	NITROGEN CYLINDER VALVE
10	NITROGEN CYLINDER
11	NITROGEN MANIFOLD
12	EXTINGUISHER PRESSURE GAUGE
13	MANUAL CONTROL VALVE HOSE REEL
14	SHUT OFF

File: 113-940

FOR MORE INFORMATION VISIT WWW.USFIREPUMP.COM

US FIRE PUMP COMPANY, LLC
 27995 James Chapel Road North, Holden, LA 70744
 MAILING: PO Box 1810, Albany, LA 70711

EMERGENCY 24 HOUR RESPONSE: (225) 209-6551



USFP-202503-6