

Foam Tender Truck

Description

The use of foam has proven itself as a force multiplier on fire scenes across the globe. Typically, numerous pieces of equipment are needed to effectively deploy firefighting foam during operations. The US Fire Pump Foam Tender is an all-in-one firefighting foam supply truck that offers all the pieces needed to deploy foam effectively and efficiently when needed.

Making use of the FoamPro Fury® direct foam injection system, the Unit can flow 250 GPM (946 LPM) of foam into the discharge outlets mounted in various locations around the apparatus.

The on-board monitor and self-educing nozzle allow accurate foam and water solution application.

Capable of carrying three (3) individual IBC totes with a total capacity of 795 Gallons (3,009 L), carrying multiple types of foam is now an option. An onboard roller assembly and quick detachment pins and bars make loading and unloading totes an easy task.

This unit is used in series with a positive pressure source or with pumps like our mobile pump units to provide the foam solution flow downstream to other delivery devices such as other monitor trailers, handheld nozzles, and other ancillary firefighting equipment.

Applications

- Industrial facilities
- Airports
- Chemical spills and other hazmat situations
- Refineries
- Emergency Response



Features

- Extruded Aluminum Body
- Enclosed side mount control panel
- Direct Inject Foam System
- Non-Skid platforms for operator safety
- Storage for adapters, hose, nozzles, tools, etc.
- SCBA Storage
- Scene lighting
- Wireless Remote-controlled Monitor (500 to 2,000 GPM)
- Commercial or Custom Chassis options
- NFPA Lighting Package

Contact a US Fire Pump Specialist for additional information and custom configurations.

FOR MORE INFORMATION VISIT WWW.USFIREPUMP.COM

US FIRE PUMP COMPANY, LLC

EMERGENCY 24 HOUR RESPONSE: (225)209-6551

27995 James Chapel Road North, Holden, LA 70744
MAILING: PO Box 1810, Albany, LA 70711

© 2025 US Fire Pump Company, LLC. All rights reserved. All specifications and other information shown were current as of document revision date and are subject to change without notice.



Technical Specifications

Model	Foam Tender Truck
Foam System	FoamPro Fury® Multipoint Injection System
Dimensions (L x W x H)	370" x 97" x 129" (940cm x 246cm x 328cm)
Estimated Weight	24,000 lbs. (13,610kg) unloaded
Standard Platform	Bed Mounted onto chassis
Foam Capacity	795 Gallons (3,009 L)
Discharge Outlets-Foam Solution Capable	(4) 2.5" NH Male or Female and (1) 6" NH Male. (1) 6" ANSI 150 flange for monitor mounting
Intake	(2) 6" NH Male and (2) 2.5 NH female auxiliary foam inlet flush connections
Flow Control	Wireless Remote Control or Manual Gear Operated monitors
Available Transportation Modes	Bumper pull trailer with 2 5/16 in. ball hitch (59 mm) or lunette eye / Pintle Hook
Foam Flow Rate	250 GPM (946 Lpm)

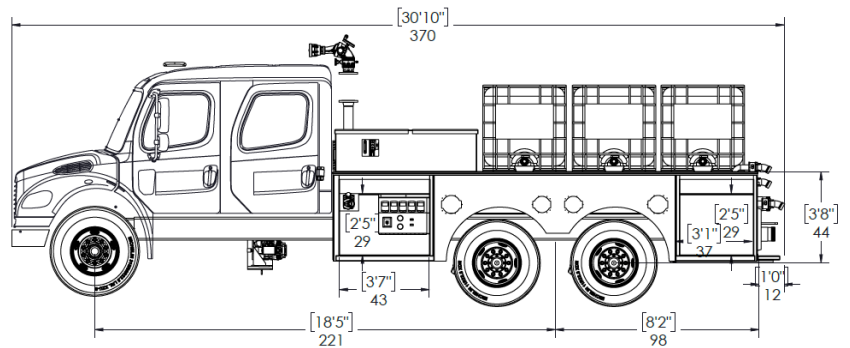
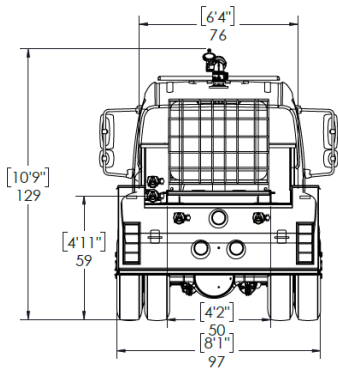

Note: *Specifications are for reference only and subject to change without prior notice. Specifications vary depending on configurations and options. Send inquiries to US Fire Pump for details.*

NOTICE Although the information and recommendations set forth herein (hereinafter "information") are presented in good faith and believed to be correct as of the date hereof, US FIRE PUMP and its affiliates makes no representations or warranties as to the completeness or accuracy thereof. Information is supplied on the condition that the persons receiving same will make their own determination as to its suitability for their purposes prior to use. In no event will US FIRE PUMP be responsible for damages of any nature whatsoever resulting from the use of or reliance upon information or the product to which the information refers. Nothing contained herein is to be construed as a recommendation to use any product, process, equipment or formulation in conflict with any patent, and US FIRE PUMP makes no representation or warranty, express or implied, that the use thereof will not infringe any patent. NO REPRESENTATIONS OR WARRANTIES, EITHER EXPRESSED OR IMPLIED, OF MERCHANTABILITY, FITNESS FOR A PARTICULAR PURPOSE OR OF ANY OTHER NATURE ARE MADE HEREUNDER WITH RESPECT TO INFORMATION OR THE PRODUCT TO WHICH INFORMATION REFERS.