

Mobile Foam Unit

Description

The Rapid-Deploy Firefighting Foam Cart is a mobile, self-contained unit engineered for fast response to hazardous material and industrial fire incidents. Designed for ease of deployment and high performance, the cart is stainless-steel in construction and has solid rubber rugged wheels for all environments. It integrates a water inlet connection for pressurized supply, and an in-line eductor system calibrated for accurate foam proportioning (3% or 6%).

The system features a high-capacity, low-expansion foam nozzle capable of delivering up to 115 GPM, ensuring effective suppression of flammable liquid fires. Quick-connect hose fittings and 2 x 50 ft of 1½” fire hose streamline deployment. Ideal for chemical plants, fuel storage sites, and transportation hubs.



Features

- Stainless- steel construction
- Lightweight and durable for rugged conditions
- Tank capacity 53 Gal (200 L)
- In-Line Eductor (3% or 6% selectable)
- Hose Storage on either side of unit
- Corrosion Resistant Frame system

Application

- Municipal Fire Departments
- Oil refineries and chemical plants
- Airports and aviation facilities
- Hazardous material response teams
- Power generation stations
- Industrial warehouses

Compatibility

These units are compatible with most firefighting foams, including our Dwight’s Signature Series and Shield Series Line of Foams! See our Foam section of our website for more information!



FOR MORE INFORMATION VISIT WWW.USFIREPUMP.COM

EMERGENCY HOUR RESPONSE: (225) 209-6551

US FIRE PUMP COMPANY, LLC
 27995 JAMES CHAPEL ROAD NORTH, HOLDEN, LA 70744
 MAILING: PO BOX 1810, ALBANY, LA 70711

© 2025 US Fire Pump Company, LLC. All rights reserved. All specifications and other information shown were current as of document revision date and are subject to change without notice.



Technical Specifications

Model	MFU - 225	MFU - 450
Flow Capacity	60 GPM @ 100 PSI (225 LPM @ 7 bar)	115 GPM @ 100 PSI (450 LPM @ 7 bar)
Tank Capacity	40, and 53 Gal optional (150, 200 L)	40, and 53 Gal optional (150, 200 L)
Inductor Inlet	2.5" FNST	2.5" FNST
Inductor outlet	2.5" MNST	2.5" MNST
Branch Pipe Inlet	2.5" FNST	2.5" FNST
Induction Rate	3% or 6% selectable	3% or 6% selectable
Material	304 Stainless-steel	304 Stainless-steel
Dimensions L x W x H	31.5" x 24" x 18.5" (800 x 600 x 740 mm)	31.5" x 24" x 18.5" (800 x 600 x 740 mm)
Finish	Painted Safety yellow or Red	Painted Safety yellow or Red

Note: Specifications are for reference only and subject to change without prior notice.
 Specifications vary depending on configurations and options.
 Send inquiries to US Fire Pump for details.

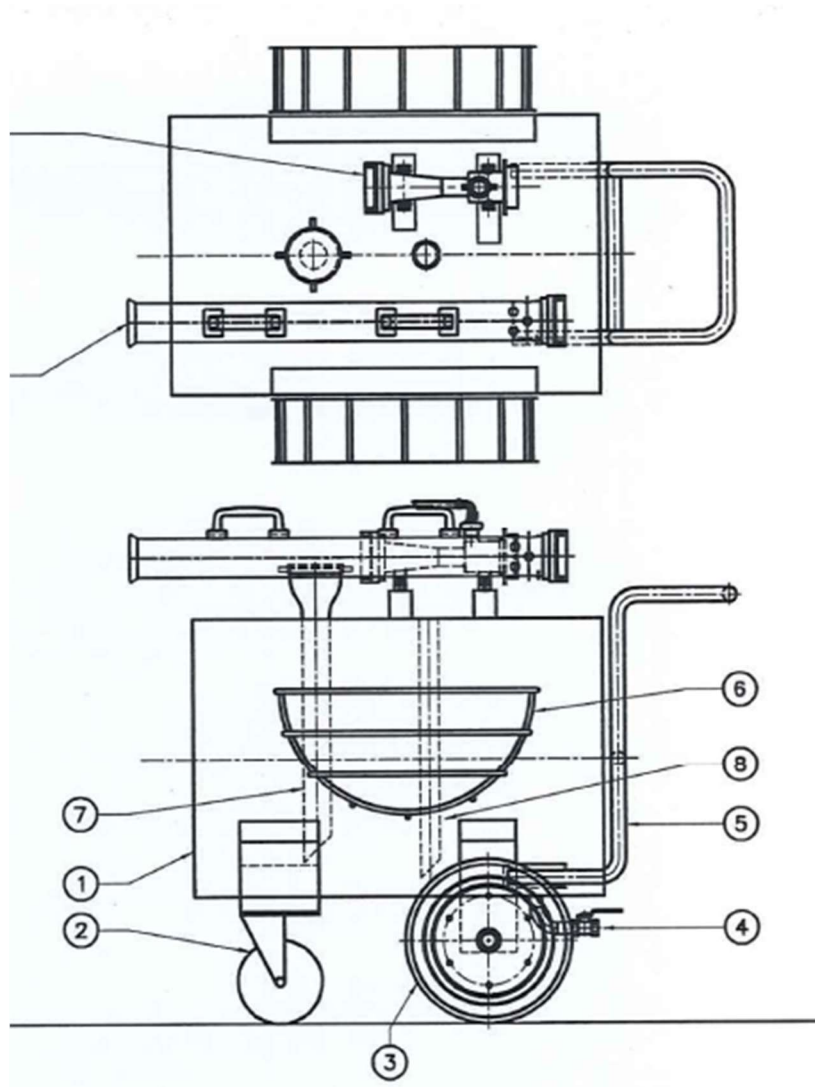

NOTICE: ALTHOUGH THE INFORMATION AND RECOMMENDATIONS SET FORTH HEREIN (HEREINAFTER "INFORMATION") ARE PRESENTED IN GOOD FAITH AND BELIEVED TO BE CORRECT AS OF THE DATE HEREOF, US FIRE PUMP AND ITS AFFILIATES MAKES NO REPRESENTATIONS OR WARRANTIES AS TO THE COMPLETENESS OR ACCURACY THEREOF. INFORMATION IS SUPPLIED ON THE CONDITION THAT THE PERSONS RECEIVING SAME WILL MAKE THEIR OWN DETERMINATION AS TO ITS SUITABILITY FOR THEIR PURPOSES PRIOR TO USE. IN NO EVENT WILL US FIRE PUMP BE RESPONSIBLE FOR DAMAGES OF ANY NATURE WHATSOEVER RESULTING FROM THE USE OF OR RELIANCE UPON INFORMATION OR THE PRODUCT TO WHICH THE INFORMATION REFERS. NOTHING CONTAINED HEREIN IS TO BE CONSTRUED AS A RECOMMENDATION TO USE ANY PRODUCT, PROCESS, EQUIPMENT OR FORMULATION IN CONFLICT WITH ANY PATENT, AND US FIRE PUMP MAKES NO REPRESENTATION OR WARRANTY, EXPRESS OR IMPLIED, THAT THE USE THEREOF WILL NOT INFRINGE ANY PATENT. NO REPRESENTATIONS OR WARRANTIES, EITHER EXPRESSED OR IMPLIED, OF MERCHANTABILITY, FITNESS FOR A PARTICULAR PURPOSE OR OF ANY OTHER NATURE ARE MADE HEREUNDER WITH RESPECT TO INFORMATION OR THE PRODUCT TO WHICH INFORMATION REFERS.