

The Monster 500lb Purple K Skid Unit

Description

A 500lb Purple K skid unit is a robust and efficient firefighting system designed for rapid deployment in industrial, aviation, and high-risk fire environments. The unit is equipped with a 500lb capacity tank filled with Purple K (PKP), a potassium bicarbonate-based dry chemical agent renowned for its effectiveness in suppressing Class B (flammable liquid) and Class C (electrical) fires. Its corrosion-resistant skid-mounted design ensures durability in harsh conditions, making it ideal for use in refineries, chemical plants, or airport fire response scenarios.

This compact yet powerful unit features a high-performance hose and nozzle system for precise application, ensuring rapid flame extinguishment while minimizing collateral damage. The skid configuration allows for easy integration onto trucks, trailers, or stationary platforms, providing flexibility and mobility for emergency response teams. With its reliable performance and user-friendly design, the 500lb Purple K skid unit is an essential asset for environments where fire safety is critical.

Nozzle options include our HG35-001 nozzle which is capable of flowing dry chemical agent through the center of a water/foam stream ranging from 60-125 GPM. See HG35-001 data sheet for more info.

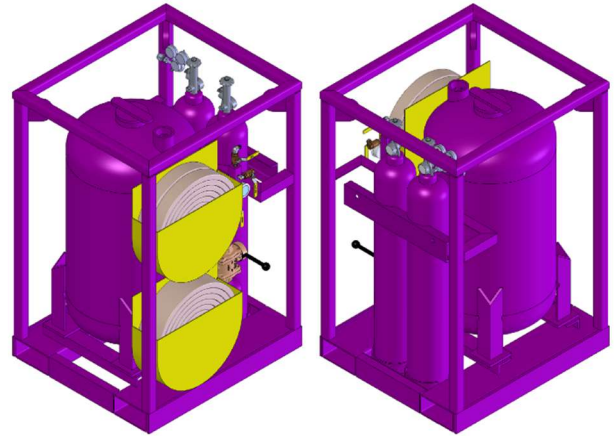

ISOMETRIC VIEWS

Features

- 500 lbs. (227 kg) of Purple K Agent
- Discharge Range: up to 60-80 ft (18.2-24.3 m)
- Available as standalone skid, Trailer unit, or in Truck unit
- Heavy Duty Steel Frame with Corrosion resistant finish
- Multiple Hose sizes and lengths available

Application

- Oil refineries and chemical plants
- Airports and aviation facilities
- Hazardous material response teams
- Power generation stations
- Industrial warehouses

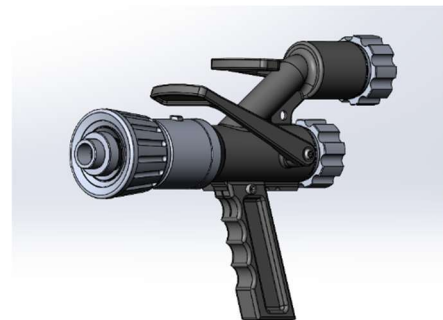

FOR MORE INFORMATION VISIT WWW.USFIREPUMP.COM

US FIRE PUMP COMPANY, LLC
 27995 James Chapel Road North, Holden, LA 70744
 MAILING: PO Box 1810, Albany, LA 70711

EMERGENCY 24 HOUR RESPONSE: (225) 209-6551



USFP-202503-6

| Technical Data | |
|----------------------------|---|
| Base Material | Carbon Steel |
| Unit Gross Weight (Loaded) | 1,300 lbs (590 kg.) |
| Unit Dimensions (LxWxH) | 32 x 36 x 50" (81.3 x 91.4 x 127 cm) subject to change depending on configuration |
| Operating Temp | 120* F |
| Nitrogen Cylinder | (2) 110 CF (3115 L) cylinders |
| Pressure Relief | 250 PSI (1723.7 Kpa) |

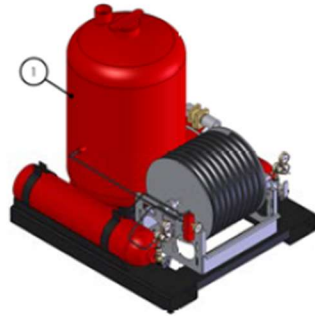
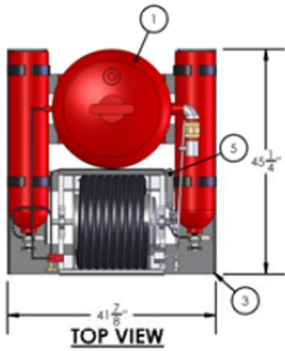

ISOMETRIC VIEW

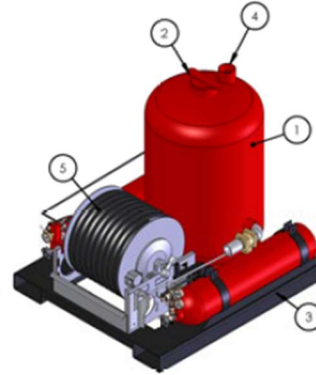

ISOMETRIC VIEW

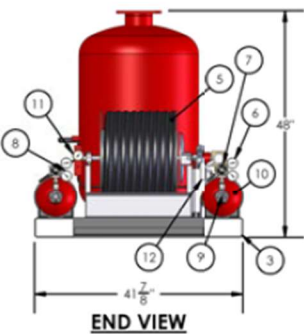

END VIEW

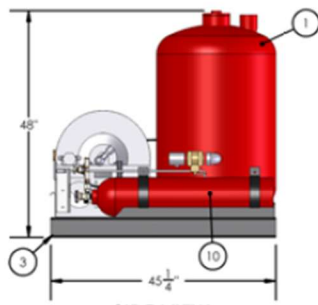

SIDE VIEW

500 lbs DRY CHEMICAL UNIT

Empty Weight - 800 lbs.

Full Weight - 1,300lbs.

| ITEM No. | UNIT DESCRIPTION |
|----------|--|
| 1 | 24" A.S.M.E. CODE CYLINDER |
| 2 | 4" FILL CAP |
| 3 | 2-110 CF EXPELLANT BOTTLESKID ASSEMBLY |
| 4 | 250 POP-OFF |
| 5 | HOSE REEL MANUAL REWIND W/ 100FT 1" HOSE |
| 6 | REGULATOR PRESSURE GAUGE |
| 7 | NITROGEN REGULATOR |
| 8 | HIGH PRESSURE GAUGE |
| 9 | NITROGEN CYLINDER VALVE |
| 10 | NITROGEN CYLINDER |
| 11 | EXTINGUISHER PRESSURE GAUGE |
| 12 | MAUAL CONTROL VALVE |
| 13 | SHUT OFF |

NOTICE Although the information and recommendations set forth herein (hereinafter "information") are presented in good faith and believed to be correct as of the date hereof, US FIRE PUMP and its affiliates makes no representations or warranties as to the completeness or accuracy thereof. Information is supplied on the condition that the persons receiving same will make their own determination as to its suitability for their purposes prior to use. In no event will US FIRE PUMP be responsible for damages of any nature whatsoever resulting from the use of or reliance upon information or the product to which the information refers. Nothing contained herein is to be construed as a recommendation to use any product, process, equipment or formulation in conflict with any patent, and US FIRE PUMP makes no representation or warranty, express or implied, that the use thereof will not infringe any patent. NO REPRESENTATIONS OR WARRANTIES, EITHER EXPRESSED OR IMPLIED, OF MERCHANTABILITY, FITNESS FOR A PARTICULAR PURPOSE OR OF ANY OTHER NATURE ARE MADE HEREUNDER WITH RESPECT TO INFORMATION OR THE PRODUCT TO WHICH INFORMATION REFERS.

FOR MORE INFORMATION VISIT WWW.USFIREPUMP.COM

US FIRE PUMP COMPANY, LLC
 27995 James Chapel Road North, Holden, LA 70744
 MAILING: PO Box 1810, Albany, LA 70711

EMERGENCY 24 HOUR RESPONSE: (225) 209-6551



USFP-202503-6